

# Perun V2 Hybrid

## User and installation manual

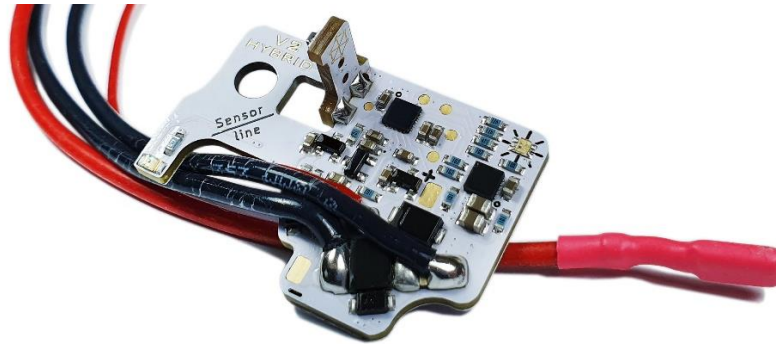

Perun V2 Hybrid replaces mechanical contacts in your airsoft replica or gel blaster and provides lots of useful features. Optical and magnetic sensors allow to eliminate many moving parts that are prone to damage, thus increasing the reliability. The elasticity of this unit gives you certainty, that replica made from parts made by different manufacturers will not have any incompatibility issues. Adaptive trigger control allows switching from a very short trigger travel to a long one even in the field, with almost any trigger, including stock ones.

Reading this manual will help you fully exploit this unit's potential and in case of encountering any problems, you can look for solutions to them here.

Manufacturer:

Perun

Barwicka 8 St.

60-192 Poznań, Poland

e-mail: [info@perunairsoft.pl](mailto:info@perunairsoft.pl)

### Table of contents

1.	Technical data.....	2
2.	How does it work?.....	3
3.	Installation.....	4
4.	During the start-up.....	6
5.	Adaptive trigger control.....	6
6.	Features and programming.....	7
7.	Factory settings.....	9
8.	Diagnostic system.....	10
9.	Sensor check.....	13
10.	Modifications needed in Krytac and other gearboxes.....	14

# 1. Technical data

## Recommended power sources

Perun V2 Hybrid works with any power source that provides a voltage between 7 and 17 volts and can deliver enough current to ensure smooth cycling of the replica. Li-Po and Li-Ion batteries with a nominal voltage of 7.4, 11.1 or 14.8 volts are recommended. It is also advised to use batteries with possibly high „C” parameter and capacity. This is safer for the battery, as it should not be working on the edge of its capability. In this video, we are showing why:

<https://www.youtube.com/watch?v=s8RKcly810A>

Capacity and the „C” parameter also influence the rate of fire of the replica:

<https://www.youtube.com/watch?v=5hO25aPvHcU>

## Compatibility with high-ROF and high-power builds

Perun V2 Hybrid can work with any replicas, including highly tuned.

## Compatible gearboxes, gears, and triggers

Perun V2 Hybrid works both in airsoft electric replicas and gel blasters. It is designed to fit version 2 gearboxes in Tokyo Marui standard. Examples of incompatible replicas are ECS series by Classic Army, EFCS by Ares, or ERG by KWA.

Perun V2 Hybrid was successfully tested in and should fit **without the need for any modification** in gearboxes made by the following manufacturers: A&K, Bolt, Classic Army (except for ECS series), G&G (with exceptions), G&P, ICS, JG, King Arms, KWA (gen 2.0), Retro Arms, Specna Arms, Ultimate, and VFC. Some grinding of the contacts area is needed in Cyma, G&G G2 and Krytac gearboxes (**see page 13**). These are gearboxes that we tested for compatibility during the design process. Please be advised, that despite our best efforts to provide reliable information, we cannot guarantee full compatibility for all the gearbox shells mentioned above. Replica manufacturers sometimes slightly change dimensions of their parts from batch to batch, bringing need for some adjustment or in extreme cases, making them incompatible with Perun V2 Hybrid.

In the G&G replicas with “45°” selector, it might be very hard to make all fire modes function properly because of a very short selector plate travel.

Gearbox color or its “shininess” has no effect on the operation of Perun V2 Hybrid.

Perun V2 Hybrid works with any gearset, including DSG, TSG, short stroked, helical, non-helical, and with any ratio. **The only exception** are 32:1 gears, that work with “half-teeth” pistons. 19-teeth sector gears (used in SR25 replicas) might need special handling when it comes to use of spring drop feature.

Stock and aftermarket triggers in Tokyo Marui standard can be used with Perun V2 Hybrid. Trigger color does not affect the operation. Some ICS triggers might require dremelling before magnet holder can be placed on them. G&G ETU triggers are incompatible and should be replaced.

## Electronic fuse

Perun V2 Hybrid has an integrated electronic fuse, which will automatically cut the power off in case of a short circuit or when a gearbox jam is detected. The fuse does not wear out when it is activated.

## Battery connector type

Perun V2 Hybrid comes with an already soldered T-Plug connector (T-Deans).

## Soldering pads for gel blasters and tracer hop-up chambers

There are two soldering pads on Perun's electronic board, designed especially for soldering the mag terminals' wires or tracer hop-up chamber wires to them.

## Stand-by current consumption

Whenever the battery is connected and selector is set to "SAFE", the mosfet consumes 1.5mA of current. While unnoticeable during normal play, it may deplete your battery completely and damage it, if you store the replica with battery connect for a week or more. Therefore, always remember to disconnect the battery after use.

## Brushless motors

Perun V2 Hybrid works with BLDC motors like Option No. 1 or Warhead. RoF reduction feature must not be activated when these motors are used.

## 2. How does it work?

Perun V2 Hybrid uses optical and magnetic sensors for the detection of sector gear, trigger, and selector plate position. It has no moving parts at all. That provides not only great reliability but also flexibility, thanks to which Perun V2 Hybrid will work without problems in almost any combination of gearbox shells, triggers, selector plates and sector gears.

### Sector gear detection

Sector gear phototransistor (sensor) and IR LED diode work in pair as a barrier switch. When sensor and diode are obstructed, it means that the gear teeth are between them. Perun V2 Hybrid is using information whether gear teeth are present or not, to determine which gearbox cycle phase is currently taking place. Algorithm used for counting teeth allows almost any gearset to be used. No adjustment needs to be made to enable compatibility with DSG, TSG, short-stroked or SR25 gears.

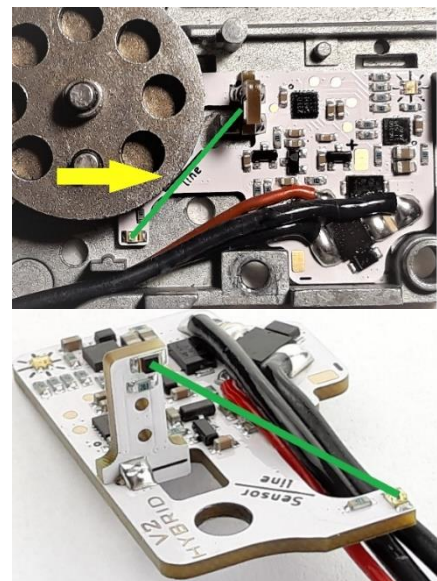

### Selector sensor

There are two selector sensors on Perun V2 Hybrid, marked blue (for semiautomatic mode) and red (for auto) on the photo to the right. These sensors work by emitting infrared (IR) radiation and detecting, how much of it is coming back to them due to reflection from nearby objects. White objects reflect most of the IR, while black almost none. Also, objects must be very close (less than 1mm) to the sensors to be detected, so lack of anything above them also results in no readings.

When the white area on the selector sticker is above the "SEMI" sensor, it is reflecting IR back to it, letting the unit know that the corresponding selector position has been set – provided that the sticker is well placed. The same principle works for "AUTO". "SAFE" is detected, when the white area on the sticker is not present above any of the sensors.

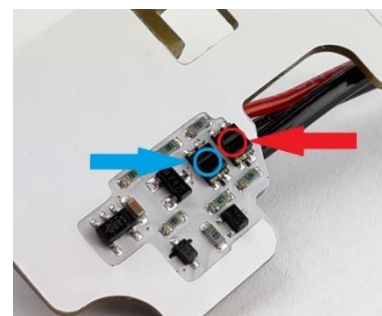

## Trigger

Hall-effect sensors are monitoring the magnetic field generated by the magnet in the magnet holder installed on the trigger. These readings are then conveyed to the microcontroller of the unit, which depending on the sensitivity setting and trigger position, may trigger a shot. The magnetic sensors are also able to detect, whether an external magnetic object is present near to the replica and in such case, will activate external magnetic field alarm to prevent an unintended shot.

## 3. Installation

Supplementary video manual is available here:

<https://www.youtube.com/watch?v=NCD2DWjRhj8>

1. Disassemble the replica and the gearbox. Remove everything from the gearbox.
2. Place Perun in the gearbox so, that the sector gear's edge would align with the *Sensor line* that is printed on the PCB, as shown on the photo to the right. Max. 0.5mm deviation to the left or right from this line is acceptable, but it is better to avoid it. When ready, screw Perun in place. Make sure it is held firmly by the screw and **does not wobble**. Do not worry about the PCB, in the screw area there are no electronic paths, and you do not need to use any gaskets. Do not use excessive force, though.
3. Install the plastic magnet holder on the trigger, as shown on the photo to the right. When screwing the two halves of the holder together, **use only little force**, not to damage the threading. Depending on the trigger model you are using, **there may and can remain a gap between the two halves**. If the magnet holder still wobbles, use the third screw to remove any remaining slack (also **be careful** and do not use excessive force on the screw).
4. Make sure that the trigger is not touching the electronic board and the sector gear can spin freely, not touching the screw. The sector gear can touch the magnet holder initially but should no longer do so after you insert the middle pin that goes through the gearbox right behind the trigger.
5. Put the selector sticker on the selector plate (remove the metal part from the plate if present), in place shown on the sticker set that came with Perun. If you are installing it in a replica manufactured by ICS or an MP5 by JG, use stickers "for ICS". The sketch below shows, how does the selector sensor work and how should the selector sticker be placed in relation to the selector

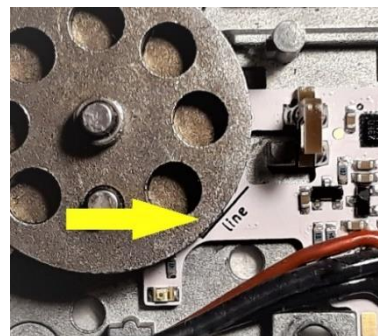

*Sensor line and sector gear alignment*



*Magnet holder*

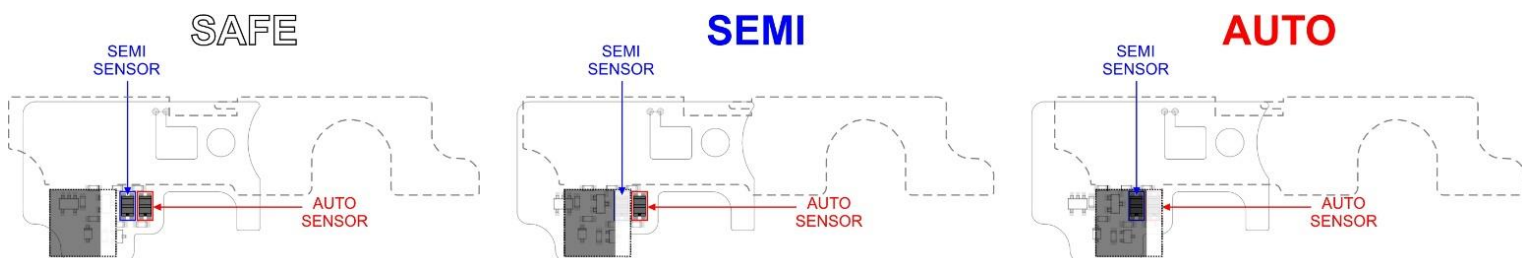

White field on the selector sticker is to the left of the semi sensor.

White field on the selector sticker is above the semi sensor.

White field on the selector sticker is above the auto sensor.

sensors:



- Assemble the gearbox only with the sector gear, Perun, and the trigger inside. It is advised to shim the trigger (standard gear shims can be used for this purpose), so that it can only move back and forth, not sideways. The trigger holder should rest on the contact stopper (a little protrusion or a screw on the gearbox), as shown on the photo:
- Put the gearbox in the lower receiver and insert the rear and middle pins. While inserting the middle pin, you might need to pull and hold the trigger, to let the middle pin go through.
- Connect the battery to the mosfet (with the motor still disconnected) and use the **Sensor check feature (more details on page 13)** to check, whether all the sensors work properly. Make sure that the selector positions are detected as shown below:

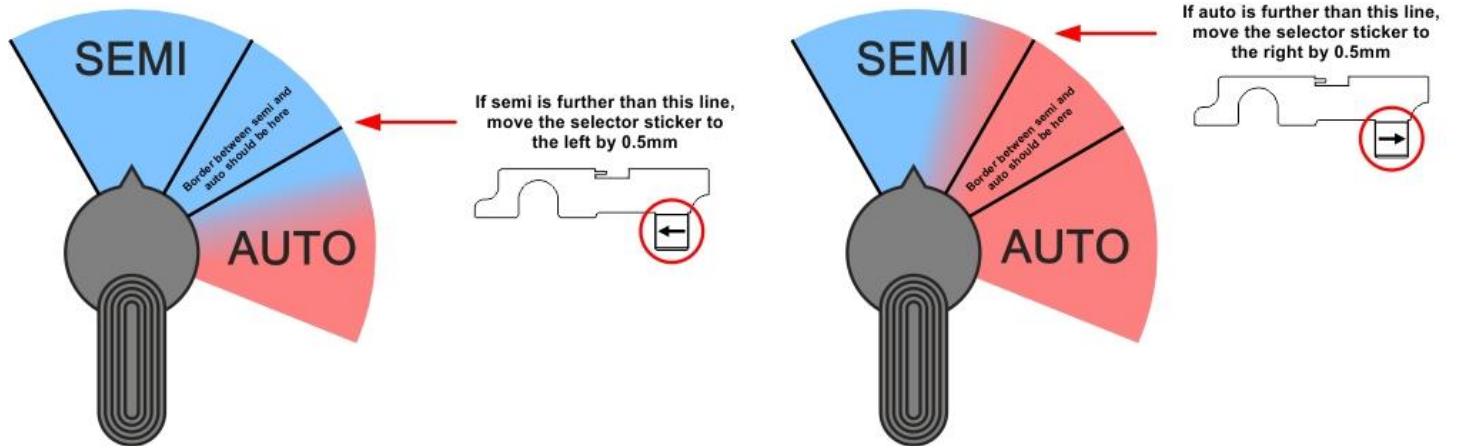

Also check the trigger and the sector gear. In case Perun does not detect trigger, sector gear, or selector positions properly at any of these trials, please refer to solutions described on the scheme above or below:

- The selector must be on "SAFE" when the battery is being plugged in.
- If the trigger does not seem to be working, make sure that the magnet together with its plastic holder is on the trigger and it is placed correctly. The correct polarization of the magnet (which end of the magnet is pointing at the board) is important.
- If the sector gear is not being detected, check whether the wires are not obstructing the IR diode in the bottom-left part of the mosfet. If the problem persists, you might need to try releasing the screw that holds the electronic board, moving the board to the sides (if possible) and then screwing it back and checking again.

- If everything works correctly, remove the gearbox from the lower receiver.

- Open the gearbox again and put the rest of the components inside. If you are installing Perun in a gel blaster or using a tracer hop-up unit, use the soldering pads on Perun's electronic board marked with "+" and "-" to solder the mag terminals' wires or tracer wires. Be careful not to accidentally solder the pads together with the adjacent components!

**Note, that you can leave the mechanical safety mechanism, if you like, it is not necessary, though.** It is a matter of your preference.

- Assemble the gearbox. Put the whole replica together. Watch out for the wires, make sure that the insulation does not get damaged during the assembly!

- It is recommended to check for any short circuits between the plugs, gearbox and body using a multimeter.

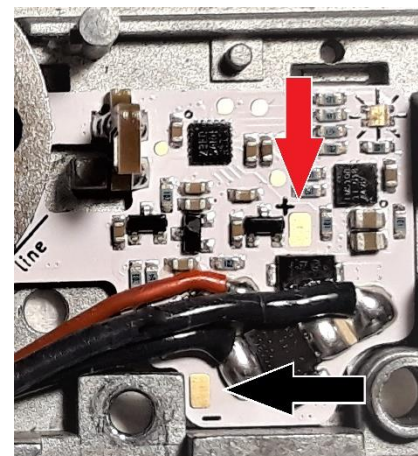

*Tracer or mag terminals soldering pads*

## 4. During the start-up

Every time, **when connecting the battery to the replica, make sure that the selector is set to “SAFE”**. This is a safety concern, but it also helps Perun find out, where the “SAFE” position is. If you will connect the battery with the selector on “SEMI” or “AUTO”, the replica may not shoot unless you switch to “SAFE” first or even if it does, the unit may sometimes function abnormally until the “SAFE” position is reached at least once.

## 5. Adaptive trigger control

Each time the battery is connected, Perun senses the trigger resting position and uses it as a reference (therefore, make sure to never pull the trigger during startup). Depending on the current trigger sensitivity setting, Perun will automatically fire after the trigger has traveled a long enough distance. This allows very short trigger pulls with no trigger modification needed whatsoever and the trigger sensitivity changes possible even in the field.

When using a trigger with regulation, only the overtravel limiter should be used. Pre-travel regulation can make the trigger pull necessary to fire a shot longer, than it would have been when left in the standard forward position. When in normal semiautomatic mode, the Perun Hybrid uses a progressive trigger activation method. This means that the trigger threshold and reset points are mobile and move together with the trigger, as shown on the sketch below:

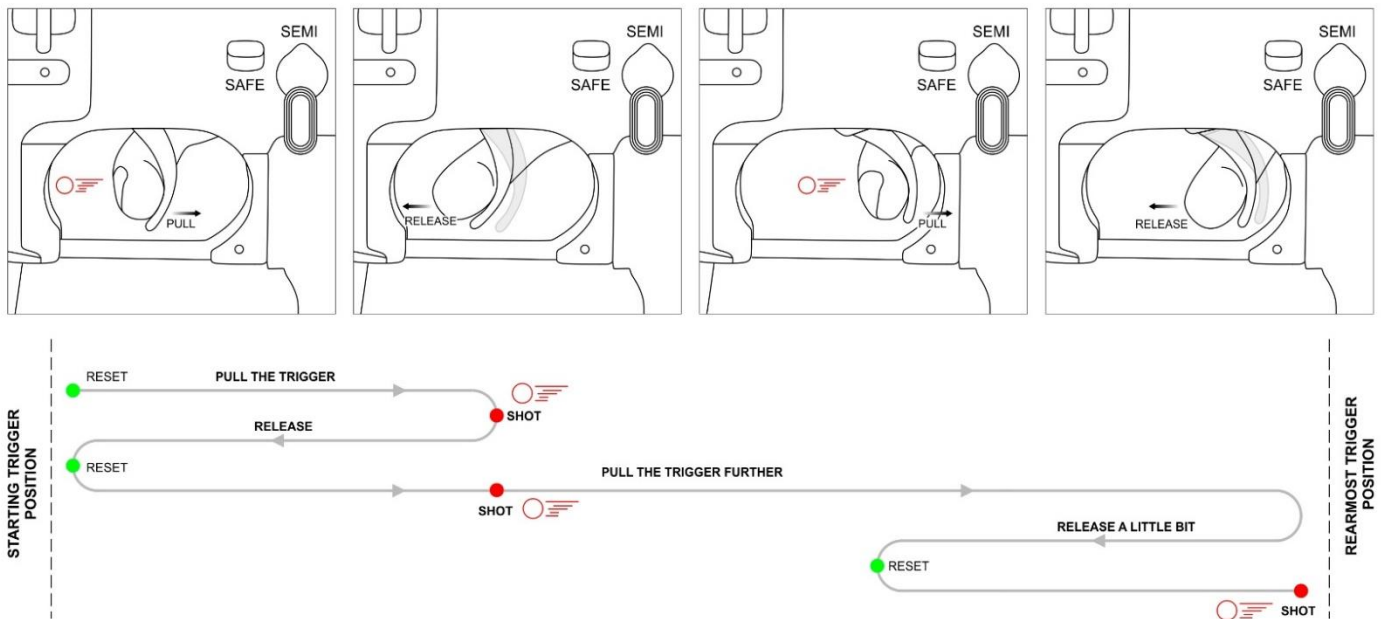

This results in two things:

1. If high trigger sensitivity is set, in most cases (depending on the trigger model) you should be able to pull the trigger all the way back and shoot by only slightly releasing it from the rearward position and pulling it again. It also allows to easily “spam” in the semiautomatic mode because you only need to quickly pull the trigger, not necessarily having to make sure it is fully released. This might be a point of interest, particularly for speedsoft players.
2. For players looking for more realism, what might be important is that the trigger must always be reset (released) a certain distance before another shot can be taken, which is noticeable at lower sensitivities. This emulates how triggers in real firearms work and provides a greater degree of control.

The progressive method does not work when burst, auto, DMR mode, binary trigger or 2-stage trigger are enabled.

## 6. Features and programming

Supplementary video manual is available here:  
<https://www.youtube.com/watch?v=2o4eWEYyw7c>













































To enter the programming mode:

**For “SEMI”** – keep the selector on “SEMI” for a couple of seconds, then go to “AUTO” and back, twice. (“SEMI” → “AUTO” → “SEMI” → “AUTO” → “SEMI”)

Successful entry into the programming mode for “SEMI” will be confirmed by **one sound signal and a blue LED light**.



**For “AUTO”** – keep the selector on “AUTO” for a couple of seconds, then go to “SEMI” and back, twice. (“AUTO” → “SEMI” → “AUTO” → “SEMI” → “AUTO”) Successful entry into the programming mode for “AUTO” will be confirmed by **three sound signals and red LED light**.





Switching the selector between “AUTO” and “SEMI” and back allows to move between the modes. Pulling the trigger allows to enable, disable, or set levels for the modes.

TO PROGRAM MODES FOR "SEMI" SELECTOR POSITION		TO PROGRAM MODES FOR "AUTO" SELECTOR POSITION	
CONFIRMATION: 		CONFIRMATION: 	
<b>FIRING MODE</b>	SAFE  → 1  → (...)  → 5  → AUTO 		
<b>AB LEVEL</b>	OFF  → 1  → 2  → (...)  → 5 		
<b>PRECOCKING</b>	OFF  → 1  → 2  → (...)  → 8 		
<b>BINARY TRIGGER</b>	OFF  → ON 		
<b>2-STAGE TRIGGER</b>	OFF  → SEMI BURST  → SEMI AUTO  → BURST AUTO 		
<b>TRIGGER SENSITIVITY</b>	1  → 2  → 3  → (...)  → 5 		
<b>ROF REDUCTION</b>	OFF  → 1  → 2  → (...)  → 5 		
<b>DMR MODE</b>	OFF  → 0,25s  → 0,5s  → 1s  → 2s  → 3s 		
<b>LI-PO ALARM</b>	OFF  → ON 		
<b>DSG</b>	OFF  → ON 		
<b>MASTER RESET</b>	OFF  → ON  (2s) (or wait 10 seconds)		
<b>EXIT</b>	<b>PERUN HYBRID</b>		





### Full feature description

All the settings are set independently for “SEMI” and “AUTO” selector positions, except for Li-Po alarm and Master reset, which work for both selector positions.

Function and LED color	Description
<b>Firing mode</b>  Green	Choose firing modes for each selector position: safe, semi, 1-5 shot burst and auto.  No sound signal, steady green light – safe 1 short single signal and blink – semi 2-5 short signals and blinks – 2-5 round burst 1 long signal and blink – auto
<b>AB</b>  Blue	Active brake (AB) stops the motor after the shot, preventing the spring from remaining in a compressed state and eliminates double shots on semi in replicas with high rate of fire (“overspin”). 5 levels of braking strength are available – from 1 (weakest braking) to 5 (the strongest). Braking can be also completely disabled. It is advised not to use braking or use it on the lowest level, if stronger braking is not necessary, as it negatively impacts the service life of motor brushes and causes increased heating. <i>Tip: Switch to semi, fire a single shot, and hold the trigger after the shot. This will cause a second single shot with strongest AB setting to be fired after 3 seconds, making sure the spring remains uncompressed. It is advised to do that when you finish shooting.</i>
	<b>Attention!</b> While precocking is on, the AB setting becomes irrelevant. However, any programmed AB setting will be stored in memory and will become effective as soon as precocking is disabled.
	No sound signal while LED glows blue means, that the active brake is disabled. 1 to 5 signals indicate braking levels from 1 (the weakest) to 5 (the strongest).

Function and LED color	Description
<b>Precocking</b>  Yellow	<p>When shooting on semi, precocking keeps the piston in the rear position, ready for the shot. This decreases the time between pulling the trigger and the actual shot, increasing realism, and giving advantage in CQB fights.</p> <p>Correct precocking level must be set individually to each replica and according to user preferences. Precocking power is automatically adjusted to battery voltage and semi or automatic shots.</p> <p><b>Tip:</b> <i>To release the spring after using precocking, switch to semi, fire a single shot, and hold the trigger after the shot. This will cause a second single shot with the strongest active brake setting to be fired after 3 seconds, making sure the spring remains uncompressed. It is advised to do that when you finish shooting.</i></p> <p>No sound signal while LED glows yellow means, that the precocking is disabled. 1 to 8 signals indicate precocking levels from 1 (the weakest) to 8 (the strongest).</p>
<b>Binary trigger</b>  Purple and teal blinking alternately	<p>The Binary trigger allows the semi shots to be triggered not only during the pull, but also the release of the trigger.</p> <p><b>Tip:</b> <i>Hold the trigger for 2 seconds to cancel the second shot.</i></p> <p><b>Attention!</b> <i>Does not work with the two-stage trigger. When the two-stage trigger is enabled, the binary trigger is automatically disabled.</i></p> <p>No sound signal while LED blinks purple and teal alternately means, that the binary trigger is disabled. 1 signal indicates activation of the binary trigger.</p>
<b>Two-stage trigger</b>  Violet and green blinking alternately	<p>The two-stage trigger allows firing in one mode after pulling the trigger slightly, and another when the trigger is pulled further. Following modes are possible:            semi → burst            semi → auto            burst → auto</p> <p>Burst count is set to 3 by default, but if burst of 2, 4 or 5 will be set in the “Firing mode”, such burst count will become active in the Two-stage trigger accordingly.</p> <p><b>Attention!</b> <i>Does not work with the binary trigger. When the two-stage trigger is enabled, the binary trigger is automatically disabled.</i></p> <p>No sound signal while the LED blinks purple and green alternately means, that the two-stage trigger is disabled. When it is enabled, sound signals resembling the active setting can be heard.</p>
<b>Trigger sensitivity</b>  Violet and yellow blinking alternately	<p>This parameter decides how sensitive is the trigger. 5 levels are available, which result with a shot after the lower tip of the trigger travels roughly:</p> <p>1 – 6 mm            2 – 4 mm            3 – 3 mm            4 – 2 mm            5 – 1 mm</p> <p><b>Attention!</b> <i>Those are approximate values and may vary depending on parts used.</i></p> <p>1 to 5 signals while the LED blinks violet and yellow alternately indicate sensitivity levels from 1 (the lowest) to 5 (the highest).</p>



Function and LED color	Description
<b>ROF reduction</b>  White	This function allows to lower the rate of automatic fire. 5 reduction levels are available: 1 – 6% 2 – 12% 3 – 18% 4 – 24% 5 – 30% <b>Attention!</b> <i>Those are approximate values and may vary depending on replica configuration.</i> <b>Attention!</b> <i>Semi-automatic shots and the first shot in burst are always fired without any power reduction to retain good trigger response.</i> No sound signal while LED glows white means, that the ROF reduction is disabled. 1 to 5 signals indicate reduction levels from 1 (the smallest) to 5 (the greatest).
<b>DMR mode</b>  Purple	DMR Mode allows only semiautomatic shots and limits their frequency as well. Its main use is for high power DMR-styled replicas on fields, which demand such limitations. 0.25s, 0.5s, 1s, 2s and 3s intervals are available.  No sound signal while the LED glows purple means, that the DMR mode is disabled. 1 to 5 signals indicate interval levels from 1 (the shortest) to 5 (the longest).
<b>Li-Po and Li-Ion alarm</b>  Teal	Li-Po and Li-Ion alarm informs the user that battery voltage has fallen below 3.7V per cell, at which the battery should not be further used and must be recharged. Unit automatically detects number of cells in the battery and determines safe voltage range. The need for battery replacement is signaled by short sound signals every 30s. Disable this function if you are using batteries other than Li-Po or Li-Ion.  No sound signal while the LED glows white means, that the alarm is disabled. 1 signal indicates activation of the alarm.
<b>DSG</b>  Green and blue blinking alternately	This function must be enabled when dual sector gear is used, to provide proper cycle control.  No sound signal while LED glows green and blue alternately means, that DSG is disabled. 1 signal indicates activation of the DSG mode.
<b>Master reset</b>  Red	Master reset returns the unit to the factory settings.  To reset, pull and hold the trigger for 2 seconds or simply wait 10 seconds while the LED glows red and until the reset takes place without using the trigger. A long sound signal confirms return to factory settings.







## 7. Factory settings



New units and units where master reset was activated will have modes set in a following way:

- Firing mode – semi on “SEMI” and auto on “AUTO”
- AB – level 3
- Precocking – disabled
- Binary trigger – disabled
- Two-stage trigger – disabled
- Trigger sensitivity – level 3
- DMR Mode – disabled
- ROF reduction – disabled
- Li-Po and Li-Ion alarm – enabled
- DSG - disabled

## 8. Diagnostic system

Perun V2 Hybrid has a diagnostic system that will help you find the source, should you encounter a problem. After the battery is connected, the unit undergoes a start-up check, to make sure replica is ready to work. Successful completion of this check is indicated by a short green blink of the LED.

Problem and LED color	Description
<b>Disconnected motor/Diagnostic mode</b>  Yellow, blinking	<p>This not only provides information about the disconnection of the motor, but it is also a diagnostic mode for the trigger, selector, and sector gear switches. With the motor disconnected, engaging the switches will cause the LED to glow purple (trigger), green (selector), or blue (sector gear) for a moment. This can be used for troubleshooting problems with the switchboard in the gearbox.</p> <p>Reconnecting the motor will restore normal function.</p> <p><b>Attention:</b> Motor check only takes place at start-up. A disconnection after the start-up will not be signaled!</p>
<b>Fuse activation</b>  Red, continuous, or blinking	<p>Activation of the fuse with a distinction between a short circuit (continuous red) and gearbox jam (blinking red). In some situations, this distinction may not be correct, for instance, a gearbox jam may be incorrectly read as a short circuit and vice versa.</p> <p>Electronic fuse might as well be activated by parts combination, which draws too much current (e.g., high speed motor and gears).</p> <p>The unit will start functioning normally after the battery is reconnected unless there still is a short circuit that will be detected at the next start-up.</p>
<b>Gearbox cycle detection failure</b>  Yellow and blue blinking alternately	<p>The unit did not receive information about cycle end from the sector gear switch and stopped firing only after safety time limit was exceeded. Check whether the gears or the sensors are not damaged and whether the sensors are properly engaged by the gears.</p>
<b>Unit temperature is too high</b>  Yellow and white blinking alternately	<p>Too high temperature of the unit (electronic board) was detected. It will not function again until it cools down, after which it will operate normally.</p>
<b>Battery with too low voltage is connected</b>  Yellow and teal blinking alternately	<p>Battery with voltage below 7V is connected. Change the battery to one with voltage between 7V and 17V.</p>
<b>Battery with too high voltage is connected</b>  Red and teal blinking alternately	<p><b>Battery with voltage over 17V is connected. The battery must be immediately disconnected, as it can cause permanent damage!</b> Change the battery to one with voltage between 7V and 17V.</p>
<b>An external magnetic field was detected</b>  Red and violet blinking alternately	<p>External magnetic field (originating not from the trigger magnet) was detected by the trigger sensors. The unit will be blocked until the source of the magnetic field is not removed.</p>

Problem and LED color	Description
<b>Main transistor or driver damage</b>  Red and yellow blinking alternately	The main transistor or driver is damaged. The unit needs to be sent back for repair.
<b>Battery voltage sensing malfunction</b>  Red and white blinking alternately	The battery detection system is malfunctioning. The unit needs to be sent back for repair.

**Other known problems:**

Problem	Cause	Solution
<b>Replica fires a 2-round burst in semi-auto mode.</b>	Motor and battery are too strong for the main spring, which causes an overspin.	Enable AB or precocking.
	Too high precocking level	Set precocking to a lower level.
	Trigger mechanism malfunction.	Check the cut-off lever and contacts, replace if needed.
<b>Replica does not shoot; the unit does not emit any light or sound.</b>	Incompatible T-Deans battery connector.	T-deans plugs and sockets from various manufacturers may sometimes not work together reliably. Although the plug may seem to fit the socket nicely, the conductive surfaces may not contact each other, cutting the power off. In that case try with another battery, most preferably with a T-deans socket made by different manufacturer.
<b>Battery and/or the motor heat up very much.</b>	The battery has too low capacity (mAh) and/or "C" parameter.	Use a battery with higher capacity and/or "C" parameter.
	The motor is too weak.	Use a stronger motor, possibly with neodymium magnets.
	Increased motor load caused by an excessive friction, for example caused by: - improper shimming, - motor positioned askew in the pistol grip.	Remove the cause of the friction.
	The motor/gear ratio/spring combination draws too much current (for instance – high speed motor, high speed gears and M120 spring).	Change the replica configuration by using a softer spring, gears with higher ratio (lower speed, higher torque) or motor with higher TPA number (or lower revolution speed).
<b>When trying to shoot, replica remains silent or shortly vibrates, after which green LED appears and one beep is heard</b>	A gearbox jam or a short-circuit is present but because of low battery power or bad connection with the battery, the unit resets due to voltage drop instead of the electronic fuse properly activating.	Remove the reason of the gearbox jam or short-circuit.
	The build is too power demanding for the battery use and the unit resets due to voltage drop.	Use a higher-powered battery.

<b>There are too many or too little shots compared to what was programmed and the cycle detection error code does not appear</b>	The sector gear is too close to the sensor line, or the gear is too dirty and prevents proper readings.	Unscrew the unit, move it to the right as far as possible and screw it back again. <hr/> Clear the sector gear of excess grease.
<b>External magnetic field error appears, despite no external magnet being close to the replica</b>	Trigger was being held at startup. <hr/> The trigger has too much slack and can move sideways, which can activate the error. <hr/> The triggers movement is obstructed and when it is released, it may end up in slightly different positions. If at some moment the trigger will move further back than it was at startup, this can activate the error.	Reconnect the battery and do not hold the trigger during the startup. <hr/> Shim the trigger so that it cannot move sideways, only back on forth. <hr/> Make sure the trigger can move freely and completely unobstructed. <hr/> Use stronger trigger spring.
<b>When RoF reduction is enabled, electronic fuse activates, or the replica just does not shoot</b>	The RoF reduction is too great, and the motor is not able to cycle the gearbox.	Reduce RoF reduction or disable it completely.
<b>In SR25 with 19-teeth gears, active brake and/or spring drop does not work properly (the piston remains precocked)</b>	Due to additional teeth, the cycle is detected too early. Perun brakes the gears fast enough to stop the sector gear just before it can release the piston to make a shot.	Enable precocking on a low level and check, whether the cycle ends where it should – with the piston in front position. Spring drop may still not work, and this method should be used instead to release the spring. If you want to have precocking during play, we advise to set high precocking for the game on semi, and low precocking on auto only for dropping the spring.
<b>Motor beeps from time to time</b>	Li-Po alarm has activated.	Replace the battery (if you're not using a Li-Po or Li-Ion, disable the Li-Po alarm).







**Attention!** In case of any technical questions, please contact us at: [info@perunairsoft.pl](mailto:info@perunairsoft.pl)

## 9. Sensor check

You can easily check the sensor readings by disconnecting the motor. When Perun V2 Hybrid is connected to the battery, but disconnected from the motor, it informs about this by yellow, flashing light. If during that flashing a properly working and connected switch will be closed, the unit will signal that by changing the LED color for a moment.

**Attention!** To enter this mode, the motor must be disconnected first, only then connect the battery!

**Attention!** After you enter the sensor check mode, it will be active for 5 minutes, after which the unit will shut down. To restart it, simply reconnect the battery.

LED color	Switch
<b>Disconnected motor / Sensor check</b>  Yellow, blinking	None of the sensors detects any change at this moment.
<b>Selector switched to "AUTO"</b>  Red	This should happen after the selector is switched to "AUTO".
<b>Selector switched to "SEMI"</b>  Blue	This should happen after the selector is switched to "SEMI".
<b>Selector switched to "SAFE"</b>  White	This should happen after the selector is switched to "SAFE".
<b>Trigger</b>  Purple	Trigger pull detected.
<b>Sector gear</b>  Green	Sector gear movement detected.

Checking the trigger and selector sensor can be done by simply pulling the trigger or switching the selector between "SAFE", "SEMI" and "AUTO" positions. This can be done without disassembling the whole replica.

To check the sector gear sensor, it is best to open the gearbox and remove everything out of it, except for Perun and the sector gear (make sure to keep the shimming the same as in assembled replica, it can influence whether the sensor would work or not). Then spin the sector gear by hand and see, whether the color of the light changes to green.



